

# GS-13/33 操作手冊

## *Operation Manual*

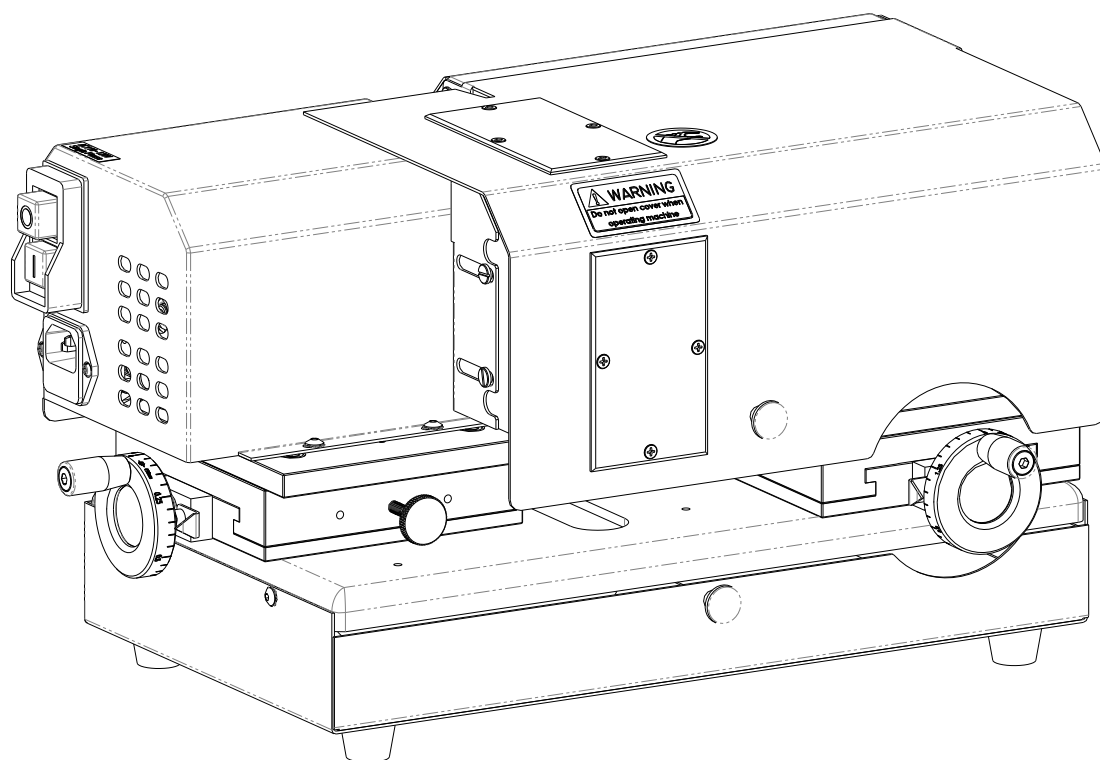

# GS13/33 各部位名稱說明 Devices and components name of Cutting Machine

## Machine

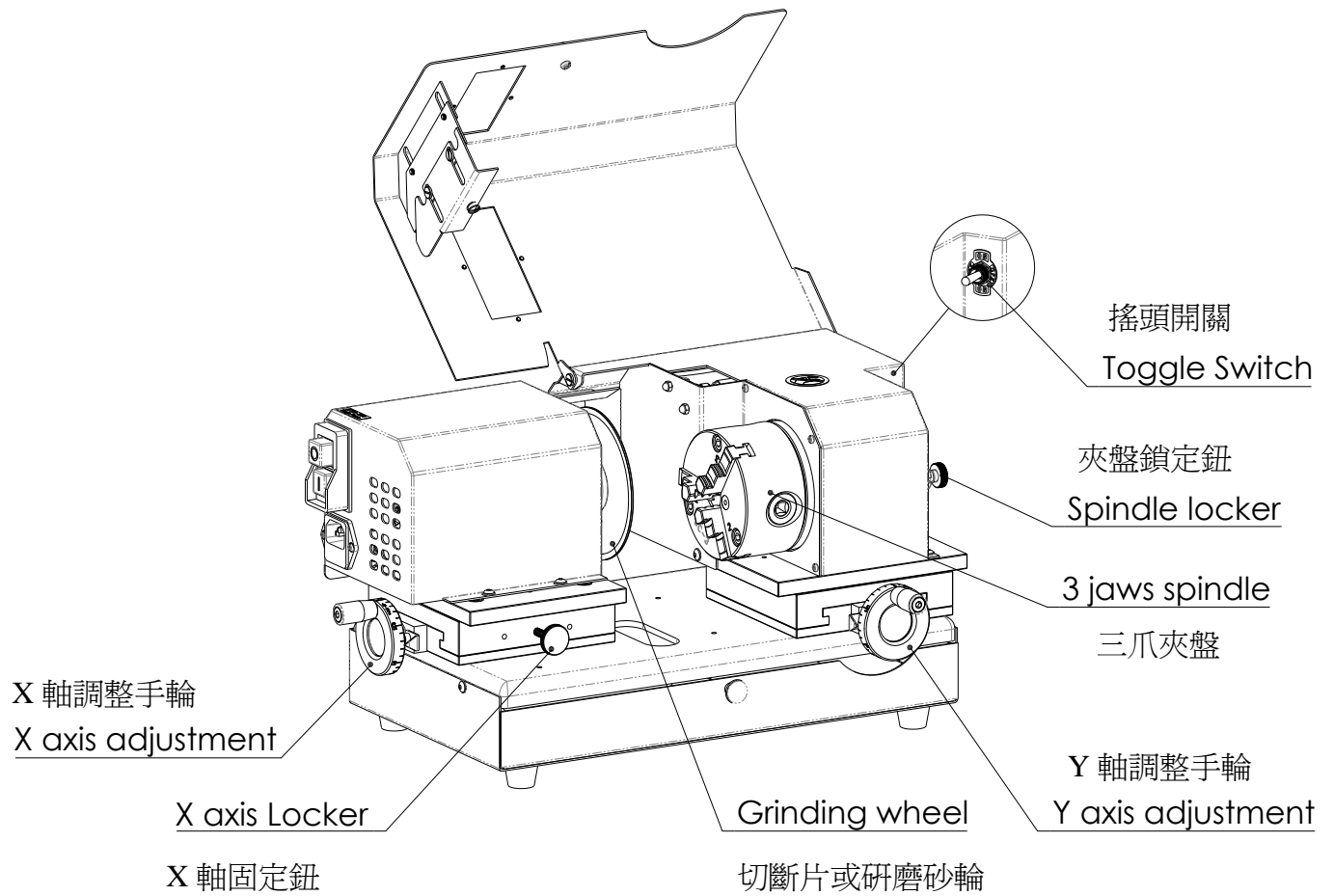

## 功能 Function

### X 軸移動調整 X axis adjustment

順時鐘旋轉手輪, X軸向左方向移動  
Clockwise the X axis wheel  
moving X axis to the left

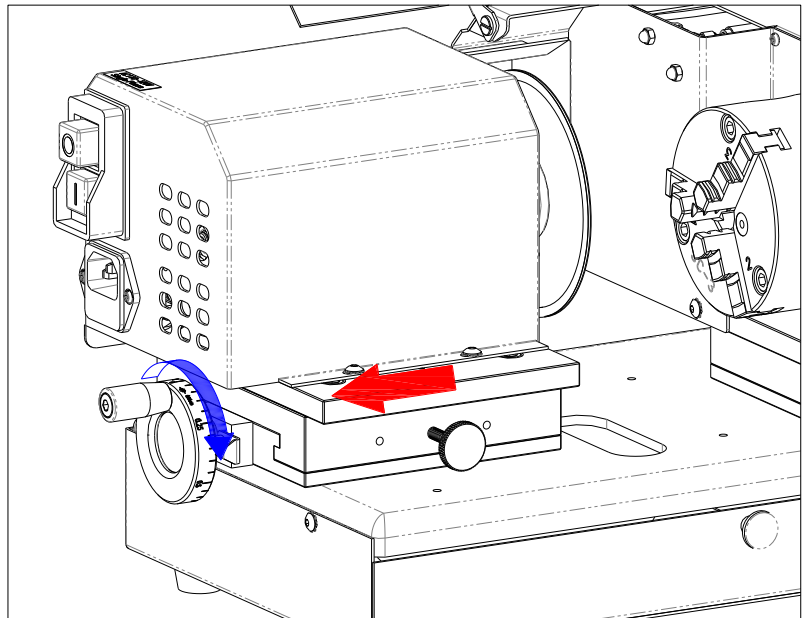

逆時鐘旋轉手輪, X軸向右方向移動  
Counterclockwise the X axis wheel  
moving X axis to the right

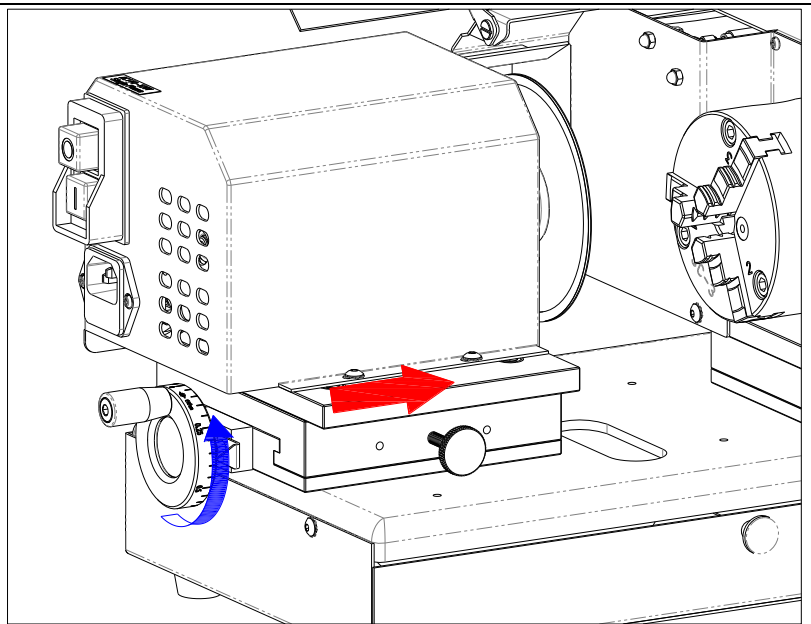

## Y 軸移動調整 Y axis adjustment

順時鐘方向旋轉手輪, Y軸向後方向移動

Clockwise the Y axis wheel  
moving backward the Y axis

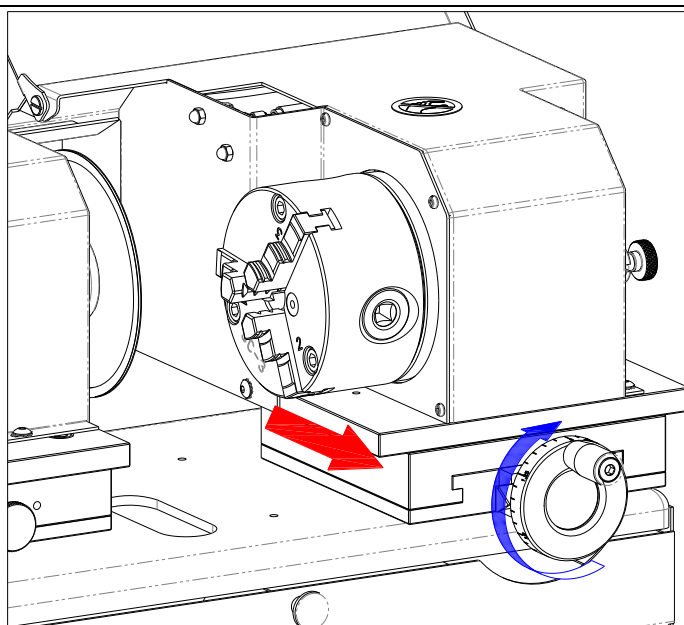

逆時鐘方向旋轉手輪, Y軸向前方向移動

Counterclockwise the Y axis wheel  
moving forward the Y axis

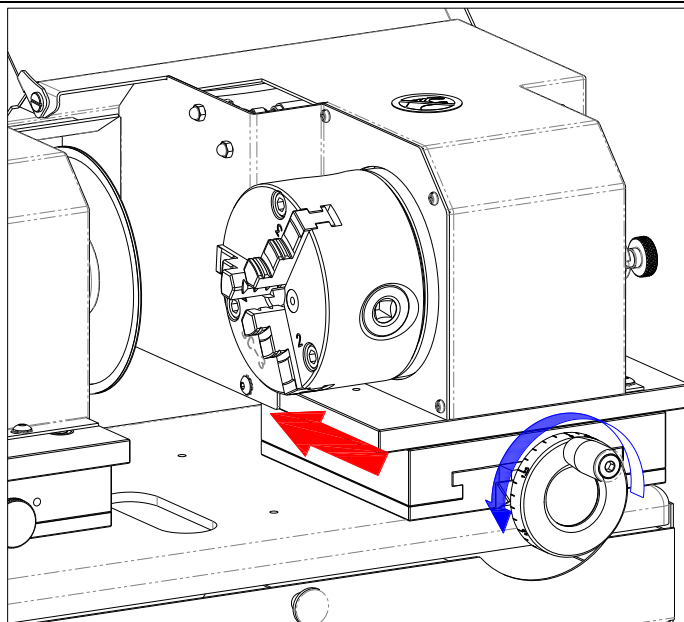

## 搖頭開關 Toggle Switch

依搖頭開關切換位置，來改變三爪夾盤是否旋轉。

The two sides motors are optional to choose working either one or both motors at a time by using the toggle switch.

搖頭開關壓至下方  
Toggle Switch to the bottom

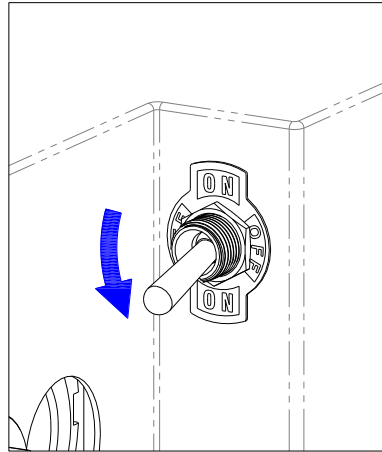

按下啓動開關  
Motor on

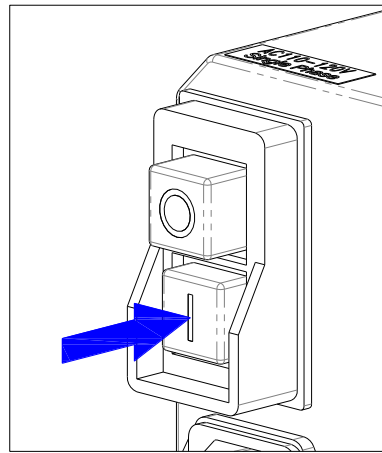

只有左馬達會運轉  
Works only the left motor

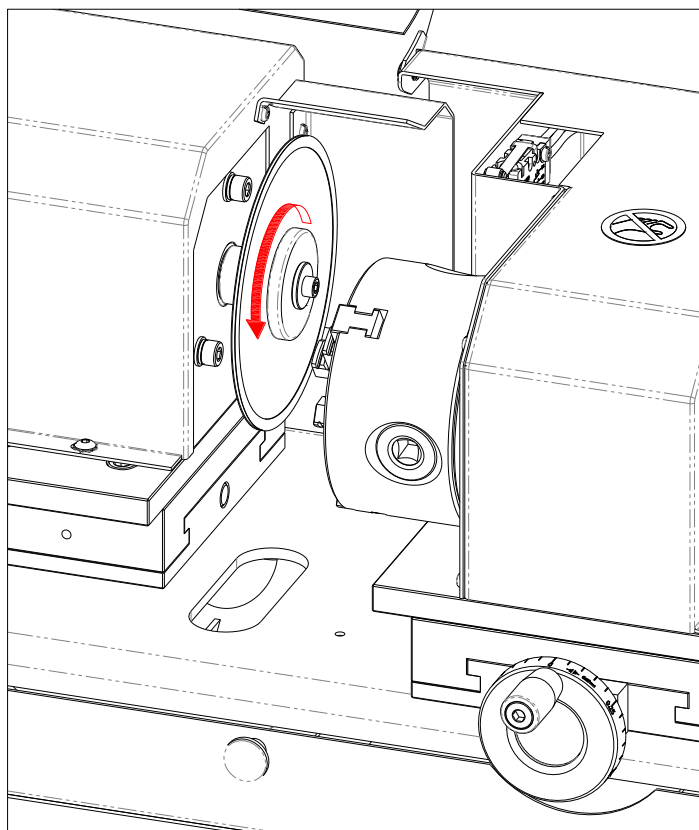

搖頭開關拉至上方  
Toggle Switch to the top

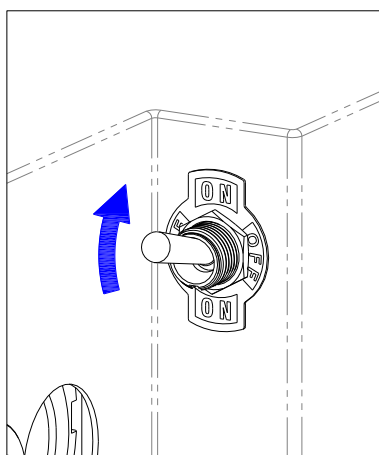

按下啓動開關  
Motor on

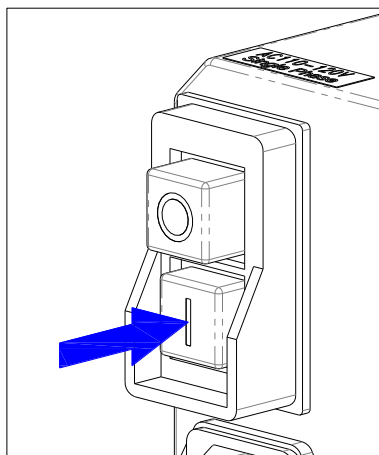

左右馬達二個都會運轉  
Works the both sides motors

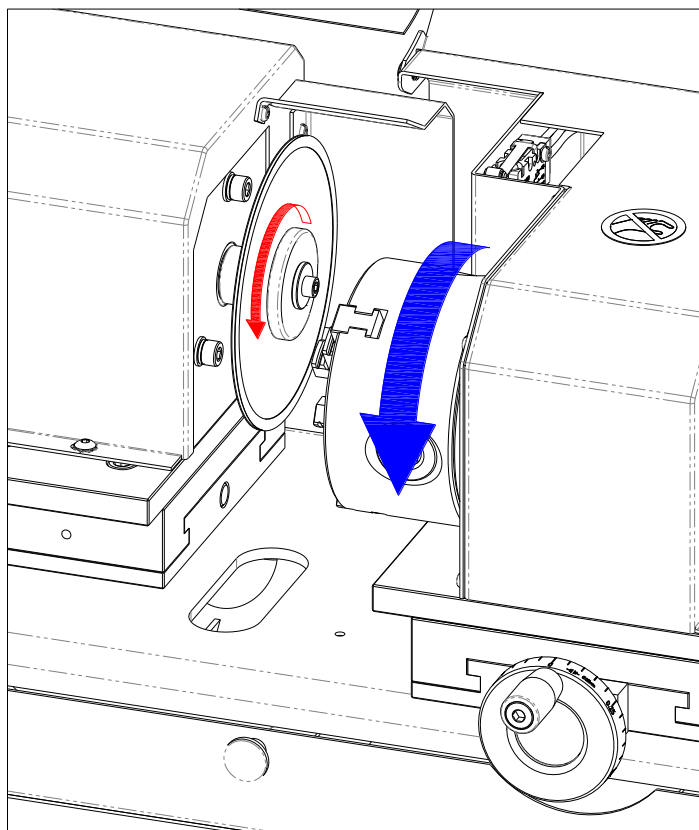

## 夾盤鎖定鈕 Spindle locker

拉出夾盤鎖定鈕90度旋轉後放入鎖定槽  
Turn Spindle locker to the other side

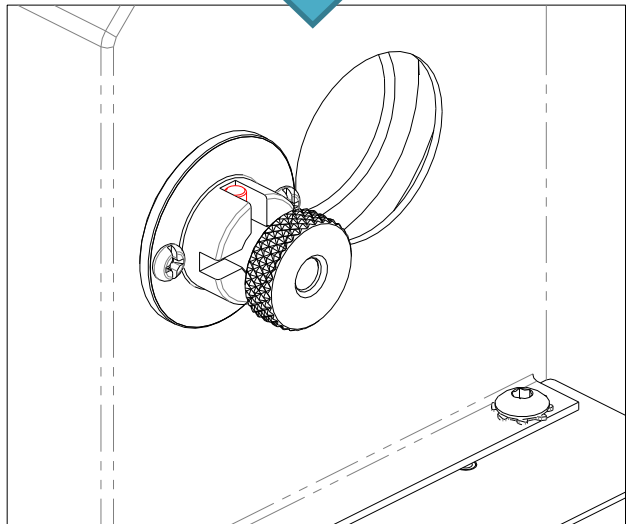
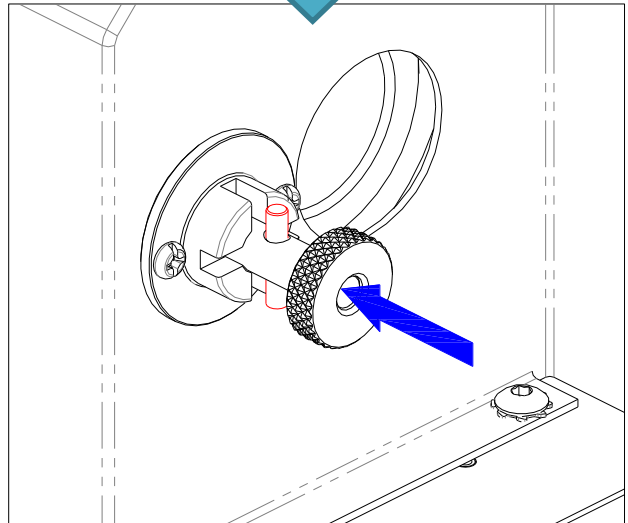
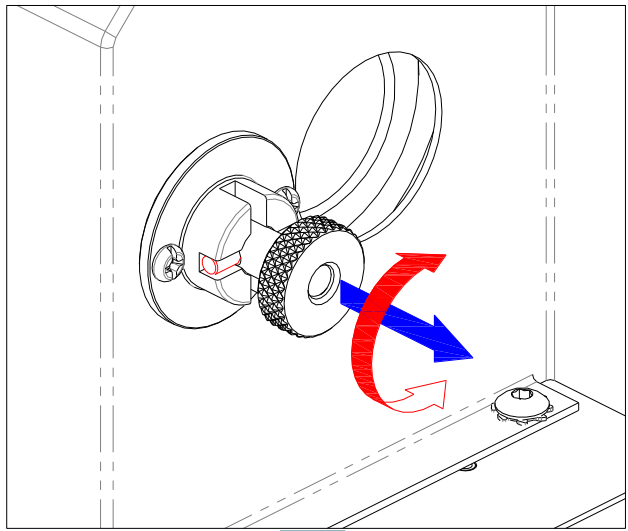



輕輕來回旋轉三爪夾盤會自動鎖定  
Turn the 3 Jaws spindle  
and lock on

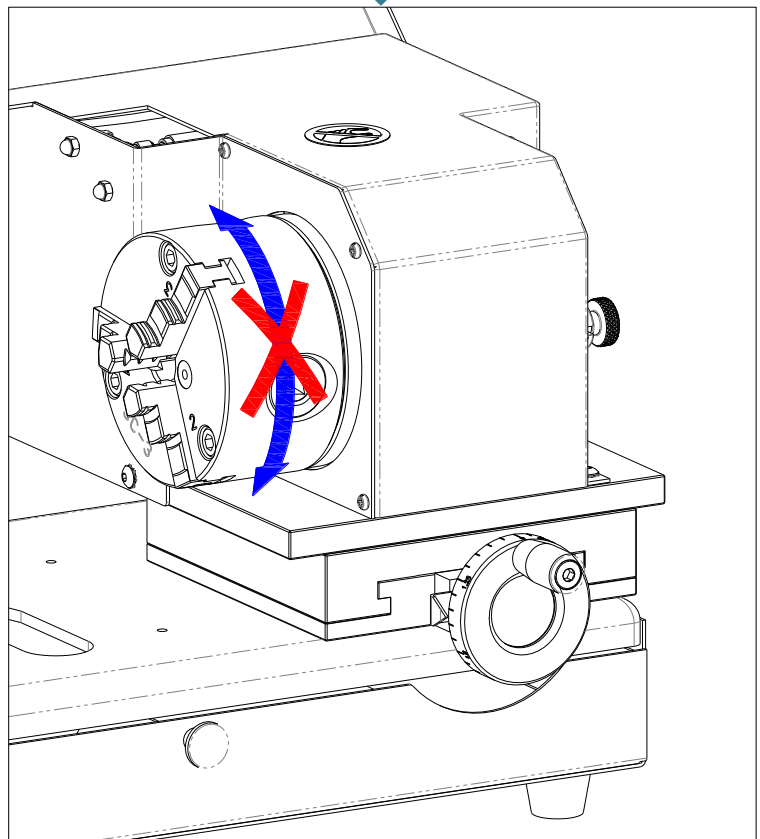
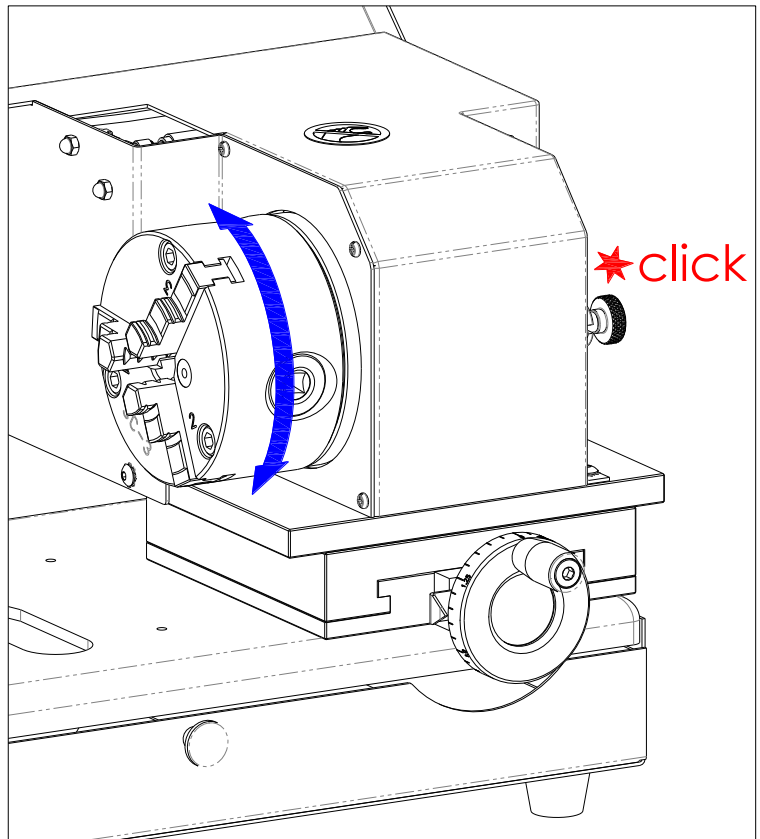

## 使用說明 Operation

選取要切斷的工件 Choose the cutting material

使用所附的T型六角扳手打開夾盤  
Open the spindle with the hand tool

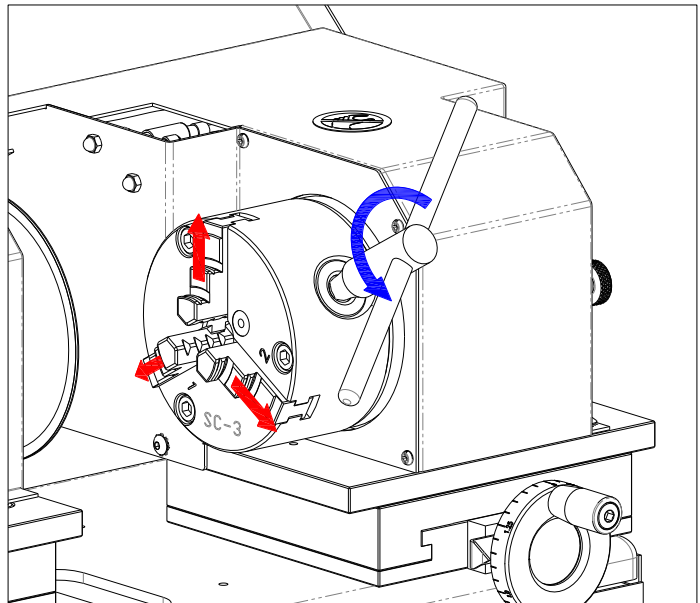

插入工件  
Insert the material

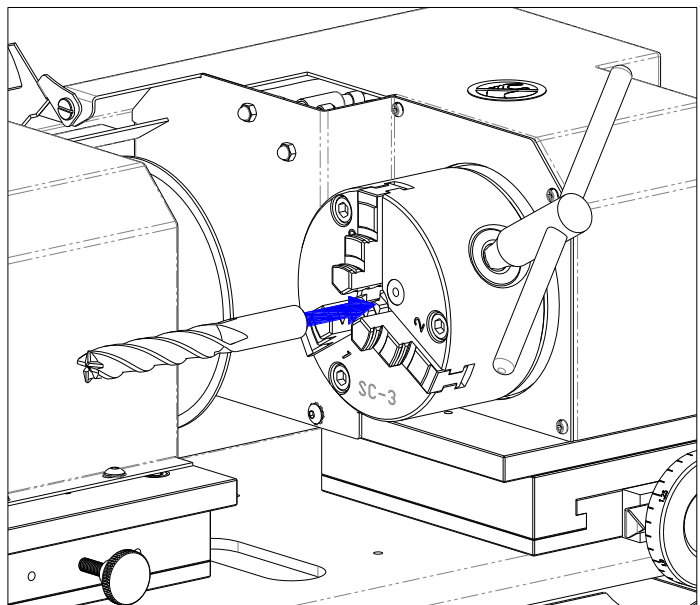

鎖緊夾盤來固定工件  
Tighten the spindle

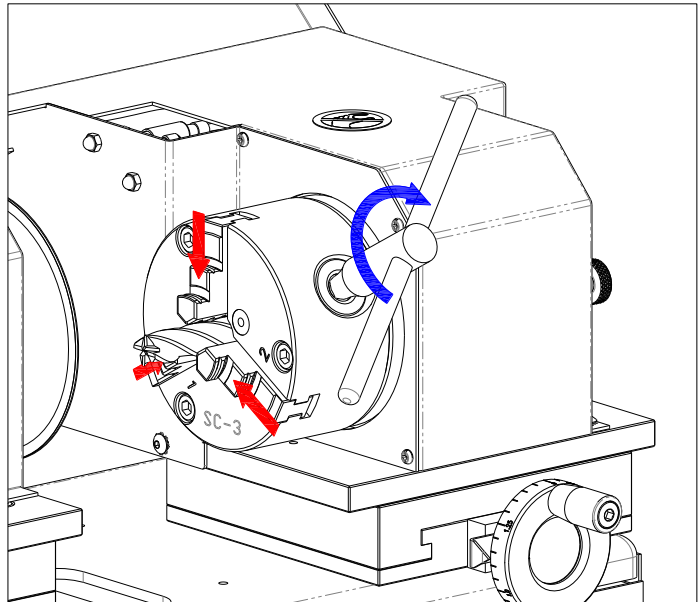

移動調整X及Y軸至所要的理想位置  
Adjust X and Y axis  
to the ideal location

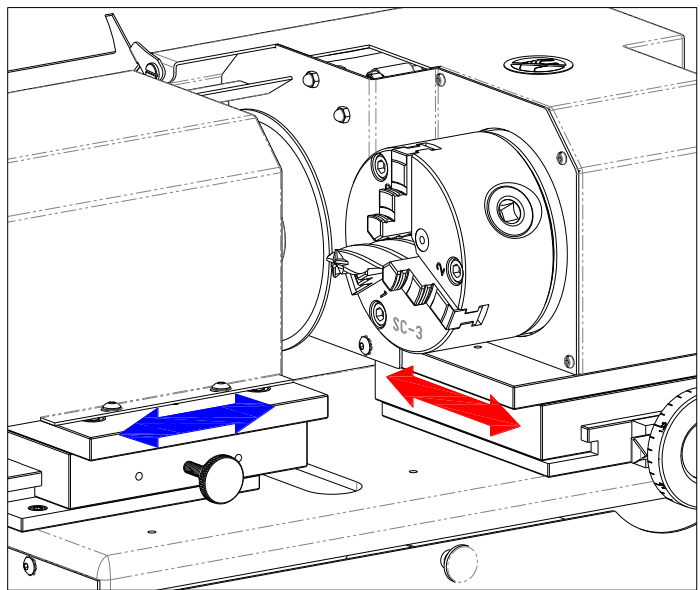

鎖緊X軸固位鈕  
Tighten the X axis Locker

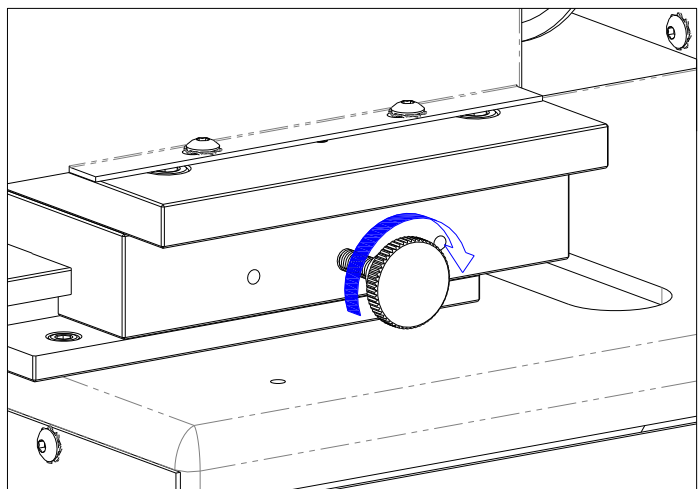

蓋上保護蓋  
Close cover

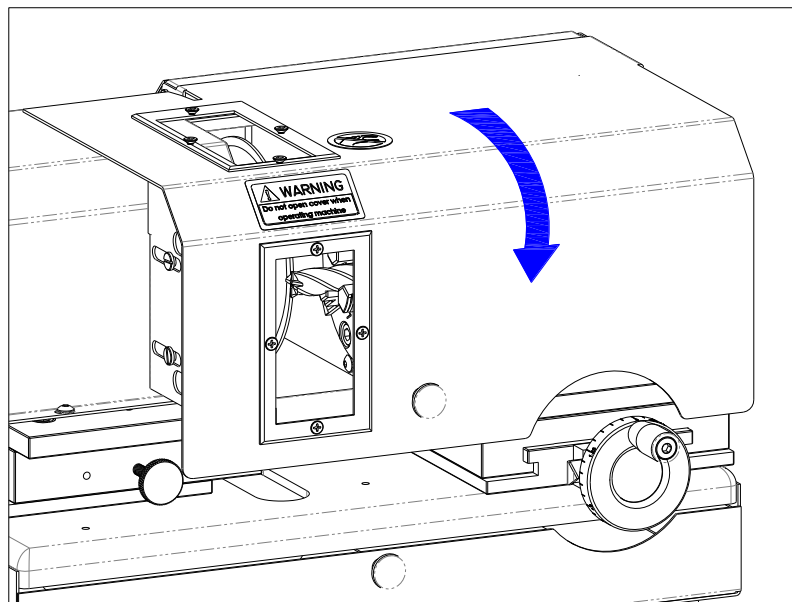

按下啓動開關  
Motor on

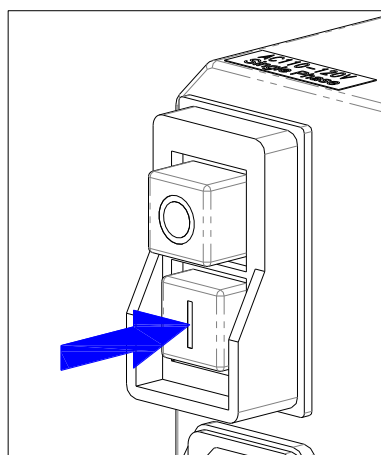

逆時鐘方向旋轉手輪直至切斷完成爲止  
Counterclockwise Y axis,  
till cutting work is completed

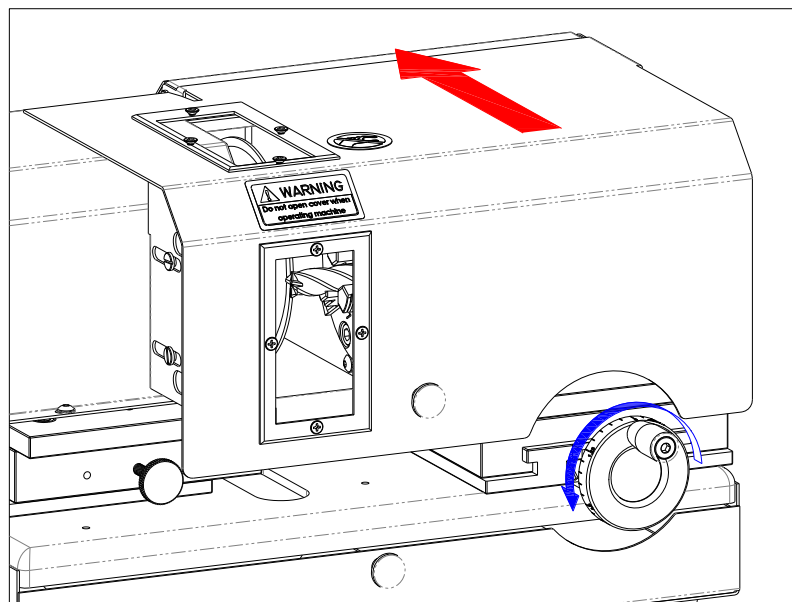

## 更換切斷片 Change of Cutting Wheel

